

---

SNOWDOGG® 16153000 HYDRAULIC REFERENCE  
XP PLOWS

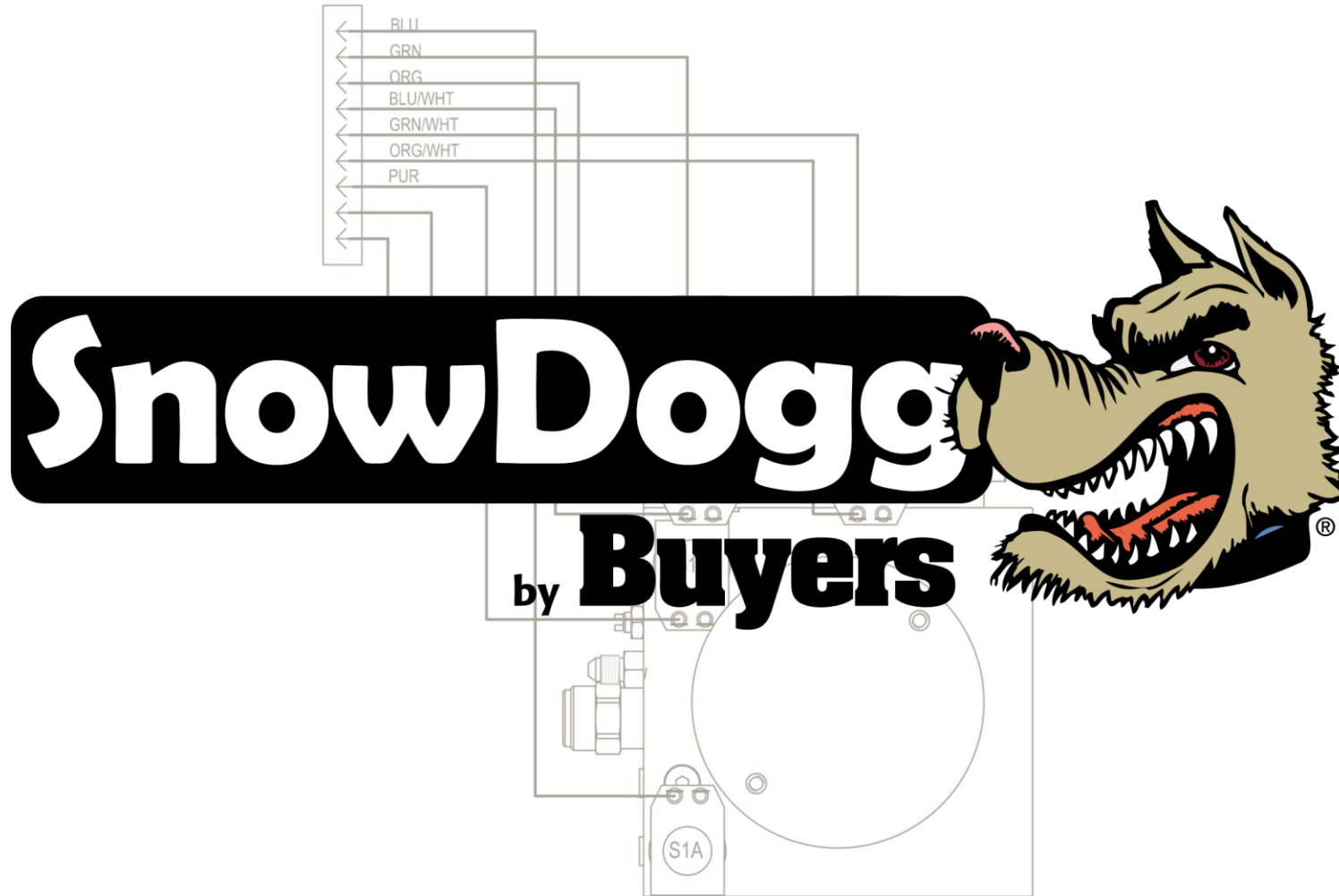

---

SNOWDOGG 16153000 HYDRAULIC REFERENCE

GENERAL REFERENCE	3
GENERAL TROUBLESHOOTING	5
HARNESS REFERENCE	14
CONTROL REFERENCE	16
HPU DECAL / QUICK REFERENCE	18

**WARNING**

ANY TROUBLESHOOTING OF THE PLOW ELECTRICAL OR HYDRAULIC SYSTEM MAY RESULT IN UNINTENDED MOTION OF THE PLOW.

ENSURE THAT THE AREA AROUND THE PLOW IS CLEAR TO AVOID PROPERTY DAMAGE OR SERIOUS INJURY

ALL MAINTENANCE MUST BE PERFORMED WITH MOLDBOARD ON THE GROUND

## GENERAL REFERENCE

---

### Note

The SnowDogg hydraulic control circuit is complete separately from the light control circuit.  
Any references to wire colors are specific to the control harness.

## Method of Operation

### Starter Relay

The SnowDogg motor starter relay is the only component of the hydraulic system mounted under the hood and is always connected. Even with the plow disconnected, the starter relay will click if the controller is powered and LIFT, LEFT or RIGHT are pressed.

### Hydraulic Solenoids

Six solenoid valves and seven coils are used in the 16153000 power unit. All use the same coil – so coils can be swapped to aid in troubleshooting. The solenoid coils act as electromagnets, and pull on an armature and spool or poppet inside the valve. A valve may malfunction due to faulty wiring, a bad coil, or contamination preventing the armature/spool from freely moving inside the valve. If the problem is contamination, it can often be corrected by removing and cleaning the valve. If the issue is electrical, the valve will not energize or shift. If the problem is mechanical, the valve may not shift or may be stuck in the shifted position.

### Controller

The hand held digital controller controls both the starter relay coil and the hydraulic solenoids. It can withstand a continuous short circuit without damage. It has integral diagnostics to aid in troubleshooting and to notify the user of an electrical fault.

## Proper Operation of Power Unit

### Controller

After hitting POWER, the SnowDogg logo should be lit and the controller status light (upper right corner) should be solid GREEN. If the status light is blinking, see troubleshooting.

### Lift Button

Plow lifts until lift cylinder is at end of stroke and fluid is diverted over the main relief valve at 1900PSI.

### Lower Button

## GENERAL REFERENCE

---

Plow drops until the blade hits the ground or until the cylinder is fully retracted.

Float (hold Lower Button for >.5 seconds)

Float light is lit and plow drops until the blade hits the ground or until the cylinder is fully retracted – and the drop valve remains energized allowing the blade to follow the ground (depending on how the chain is set).

Right Center Button (Angle Right)

The plow turns to the right – left cylinder extends and right retracts. When cylinder reaches end of stroke, motion will stop, and fluid is diverted over the main relief valve at 1900 PSI.

Left Center Button (Angle Left)

The plow turns to the left – right cylinder extends and left retracts. When cylinder reaches end of stroke, motion will stop, and fluid is diverted over the main relief valve at 1900 PSI.

Right Wing Out Button

Right wing extends. At end of stroke, motion stops, and fluid is diverted over the main relief valve at 1900 PS.

Left Wing Out Button

Left wing extends. At end of stroke, motion stops, and fluid is diverted over the main relief valve at 1900 PS.

Right Wing In Button

Right wing retracts. At end of stroke, motion stops, and fluid is diverted over the main relief valve at 1900 PS.

Left Wing In Button

Left wing retracts. At end of stroke, motion stops, and fluid is diverted over the main relief valve at 1900 PS.

Left Wing In AND Right Wing In

Both Left wing and Right wing fully retract. At end of stroke, motion stops, and fluid is diverted over the main relief valve at 1900 PSI.

Left Wing Out AND Right Wing Out

Both Left wing and Right wing fully extend. At end of stroke, motion stops, and fluid is diverted over the main relief valve at 1900 PSI.

## TROUBLESHOOTING

---

### Troubleshooting Tips

- Check for magnetism at the coils with a screwdriver or metal tool. With the coil energized, you should feel a magnetic pull at the top of the coil.
- If the controller is blinking, the problem is electrical – not hydraulic. Do not spend time troubleshooting and cleaning valves if the controller is blinking.
- Use a test light to measure for +12V at coils and connectors.
- Use a multimeter/ohmmeter to measure for continuity.
- Always start troubleshooting with the moldboard straight and on the ground.

### Tools Recommended

- Multimeter (Voltmeter/Ohmmeter)
- Wrenches
- 7/8" deep socket (for solenoid valves)
- Picks (for removing/replacing o-rings)
- SnowDogg High Performance Hydraulic Fluid (P/N 16150010)

TROUBLESHOOTING

Symptom/Diagnostic		Result	Fix
Pump motor not running when UP, LEFT or RIGHT pressed			
	Status light blinks 1 or 3 times	Continuity Problem	Check RED WIRE/MOTOR RELAY
	Check voltage at MOTOR terminals with UP, LEFT, or RIGHT buttons pressed	If voltage present - MOTOR is bad	Replace MOTOR
	Check cable continuity between MOTOR RELAY and MOTOR	If no continuity, check cable, connections, and replace if necessary	Replace/repair cable or connections
	Check control signal to MOTOR RELAY (small wires to motor relay) with UP, LEFT, or RIGHT buttons pressed	If voltage present and no click is heard when buttons are pressed, MOTOR RELAY is bad	Replace MOTOR RELAY
	Check ground continuity between control ground at MOTOR RELAY and battery ground	If no continuity, check cable, connections, and replace if necessary	Replace/repair cable or connections
Plow won't move at all, moves "jerkily", very slowly, or chatters			
	Check fluid level in reservoir	Fluid should be visible in elbow fitting.	Add fluid
	Air in fluid	Bleed air from system	Slightly loosen fittings to angle cylinders and move the plow wings. Tighten fittings while fluid is escaping. Do this over an absorbent mat, or hold a rag over fitting to absorb excess fluid.
Oil is leaking from cylinders			
		Packing is loose	Tighten gland until leak stops
		Rods are pitted	Polish rods with fine steel wool
			Replace cylinder

## TROUBLESHOOTING

Symptom/Diagnostic		Result	Fix
Oil sprays out of vent port in power unit			
	Air in Fluid	Bleed air from system	Slightly loosen fittings to angle cylinders and angle the plow. Tighten fittings while fluid is escaping. Do this over an absorbent mat, or hold a rag over fitting to absorb excess fluid.
	Check fluid level	Fluid should be visible in elbow fitting.	Remove fluid if necessary - in most cases the problem will subside as entrapped air dissipates.
	Breather clogged	Breather creating excessive pressure in reservoir	Remove/Replace/Clean breather
Plow won't drop			
	Status light blinks 3 or 8 times	Continuity Problem	Check PURPLE WIRE/S1B COIL
	Check voltage at S1B VALVE coil	If no voltage present, check cable and connections	Replace/repair cable or connections
	Check DROP SPEED control valve	DROP SPEED valve should be several turns from fully closed	Open DROP SPEED valve
	Check S1B VALVE for contamination	Poppet must move freely, and seat area must be clear of any debris	Remove S1B VALVE and check free movement of poppet, clean any chips/debris from poppet seat
			Replace S1B VALVE
	Check LIFT LOCK valve for contamination	Poppet must move freely, and seat area must be clear of any debris	Remove LIFT LOCK valve and check free movement of poppet, clean any chips/debris from poppet seat
			Replace LIFT LOCK valve
Plow won't lift			
	Status light blinks 2 or 3 times	Continuity Problem	Check BLUE WIRE/S1A COIL
	Check voltage at S1A VALVE coil	If no voltage present, check cable and connections	Replace/repair cable or connections
	Check S1A VALVE for contamination	Poppet must move freely, and seat area must be clear of any debris	Remove S1A VALVE and check free movement of poppet, clean any chips/debris from valve
			Replace S1A VALVE

TROUBLESHOOTING

Symptom/Diagnostic		Result	Fix
Left or Right Wing won't extend			
	Status light blinks 3 or 6 times	Continuity Problem	Check GRN/WHT WIRE/S5 VALVE
	Status light blinks 3 or 7 times	Continuity Problem	Check ORG/WHT WIRE/S6 VALVE
	Check voltage at S5 (LEFT) or S6 (RIGHT) VALVE coil	If no voltage present, check cable and connections	Replace/repair cable or connections
			Confirm GRN/WHT wire at S5 VALVE Confirm ORG/WHT wire at S6 VALVE
	Check S5/S6 VALVE for contamination	Spool must move freely, and seat area must be clear of any debris	Remove S5 or S6 VALVE and check free movement of spool, clean any chips/debris from valve Replace S5/S6 VALVE
Left or Right Wing won't retract but extend properly			
	Status light blinks 3 or 5 times	Continuity Problem	Check BLU/WHT WIRE/S4 VALVE
	Check voltage at S4 (LEFT)	If no voltage present, check cable and connections	Replace/repair cable or connections
			Confirm BLU/WHT wire at S4
	Check S4 VALVE for contamination	Spool must move freely, and seat area must be clear of any debris	Remove S4 VALVE and check free movement of spool, clean any chips/debris from valve Replace S4 VALVE
"Angle Left" doesn't work			
	Status light blinks 3 times	Continuity Problem	Check BLUE WIRE/S2 COIL
	Check voltage at S2 VALVE coil	If no voltage present, check cable and connections	Replace/repair cable or connections
			Confirm BLUE wire at S2 COIL
Check S2 VALVE for contamination	Spool must move freely, and seat area must be clear of any debris	Remove S2/S3 VALVE and check free movement of spool, clean any chips/debris from valve Replace S2/S3 VALVE	
"Angle Right" doesn't work			
	Status light blinks 3 or 4 times	Continuity Problem	Check GRN WIRE/S3 COIL
	Check voltage at S3 VALVE coil	If no voltage present, check cable and connections	Replace/repair cable or connections
			Confirm GREEN wire at S3 COIL
Check S3 VALVE for contamination	Spool must move freely, and seat area must be clear of any debris	Remove S2/3 VALVE and check free movement of spool, clean any chips/debris from valve Replace S2/S3 VALVE	

TROUBLESHOOTING

---

Symptom/Diagnostic		Result	Fix
Plow drifts while plowing snow			
	Air in Fluid	Bleed air from system	Slightly loosen fittings to angle cylinders and angle the plow. Tighten fittings while fluid is escaping. Do this over an absorbent mat, or hold a rag over fitting to absorb excess fluid.
	Check RELIEF valves for contamination	Poppet must move freely, and seat must be clear of any debris	Remove RELIEF valves and clean
			Replace RELIEF valves
	Damaged O-Rings	Check seals on S2/S3 Valve	Replace o-rings on S2/S3 VALVE

## HPU Servicing

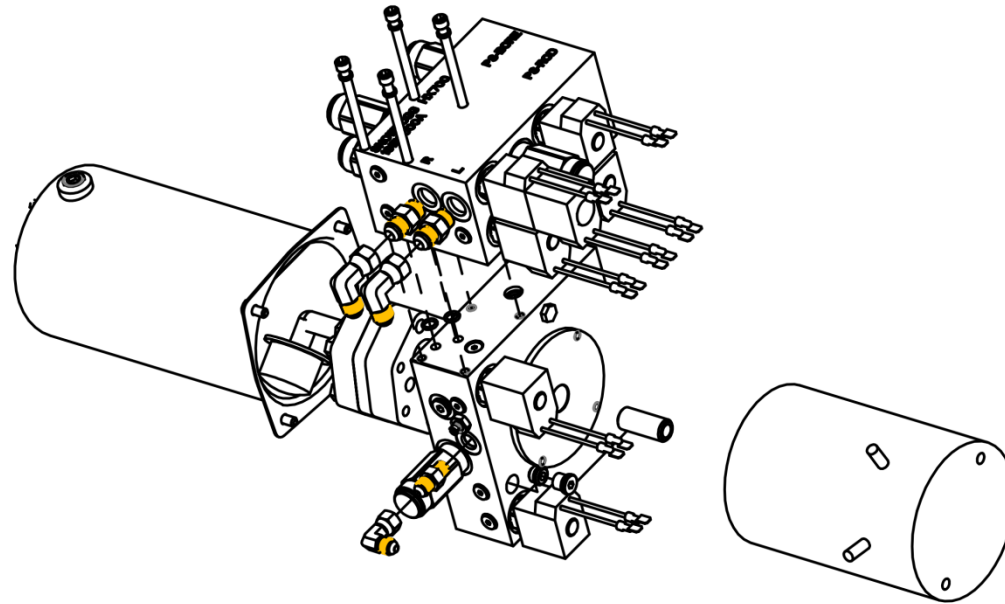

### Fill Procedure

1. Remove the fill plug from the reservoir.
2. Fill to fill plug port

### Solenoid Valve service/replacement

1. Remove the coil from the solenoid valve.
2. Using a deep socket, remove the solenoid valve from the manifold.
3. Inspect the valve for contamination or damage.
4. Ensure that the poppet or spool travels freely.
5. Flush the valve if necessary to remove contamination.
6. Reinstall valve and tighten to 20 ft-lbs.

### General valve service/replacement

1. Using a socket, remove the valve from the manifold.
2. Inspect the valve for contamination or damage.
3. Ensure that the poppet or spool travels freely.
4. Flush the valve if necessary to remove contamination.
5. Reinstall valve and tighten to 20 ft-lbs.

NOTE: Always lubricate components with oil prior to reassembly to prevent damage to the o-rings.

**WARNING**

ANY TROUBLESHOOTING OF THE PLOW ELECTRICAL OR HYDRAULIC SYSTEM MAY RESULT IN UNINTENDED MOTION OF THE PLOW.

ENSURE THAT THE AREA AROUND THE PLOW IS CLEAR TO AVOID PROPERTY DAMAGE OR SERIOUS INJURY

ALL MAINTENANCE MUST BE PERFORMED WITH MOLDBOARD ON THE GROUND

**TS1 HPU Motor not running**

1. With controller on, press LIFT, LEFT or RIGHT. Listen for starter relay "CLICK"
  - a. Click not heard
    - i. Check for +12V at relay control terminals (small terminals)
    - ii. Ground for relay should be direct to battery
  - b. Click heard
    - i. Continue
2. Jump the large terminals of the starter relay with a large wire or screwdriver.
  - a. If HPU motor runs
    - i. Replace starter relay
  - b. If HPU motor does not run
    - i. Continue
3. Disconnect plow – check for +12V at large sockets of grill connector (truck side controller harness)
  - a. If +12V is not present
    - i. Check wiring continuity between starter relay and grill connector and battery ground and grill connector
  - b. If +12V is present
    - i. Continue
4. Check continuity between plow side connector and studs on HPU motor
  - a. If continuity is NOT found
    - i. Check wires
  - b. If continuity is found
    - i. Continue
5. Disconnect Red wire from HPU motor, directly apply +12V to HPU motor (from extra battery or using jumper cables)

## TROUBLESHOOTING

---

- a. If motor runs
  - i. Motor is not defective, check wiring
- b. If motor does not run
  - i. Motor is defective, replace

### TS2 General Coil Troubleshooting – Blinking Status Light

1. Turn Controller OFF, waiting five seconds, turn Controller ON
2. Hit UP/LEFT/RIGHT/DOWN in sequence and watch the plow.
  - Plow is operating correctly / status light is not blinking  
Complete
  - Plow is operating correctly / status light IS blinking  
There is an intermittent short/open circuit.  
Clean and check all connection points  
Look for frayed/pinched/damaged wires  
Continue
  - Plow is NOT operating correctly / status light IS blinking  
Continue
3. Check for +12V at coil terminals
  - If +12V is present  
Coil is defective, replace
  - If +12V is not present  
Check ground side wire continuity  
Continue
4. Check for continuity on +12V wire between coil and grill connector (see pinout)
  - If continuity is NOT found  
Repair/replace plow side harness
  - If continuity is found  
Continue
5. Check for continuity between grill connector and controller connector (in cab)
  - If continuity is NOT found  
Repair/replace truck side control harness
  - If continuity is found  
Check controller connector pins and verify everything is seated properly.

## TROUBLESHOOTING

---

Try a known good controller

6. Contact SnowDogg Tech Support

### TS3 System Pressure Check

1. Disconnect the lift cylinder hose from the manifold
2. Install a pressure gage on the lift port
3. Energize the LIFT circuit and read the gage pressure
  - a. Pressure is over 1700 PSI
    - i. Pressure is correct
  - b. Pressure is under 1700 PSI
    - i. Replace/clean the Main Relief Valve

## TRUCK SIDE HARNESS PINOUT

16160302 TRUCK HARNESS TO  
16162601B G2 CONTROLLER  
(HARNESS SIDE)

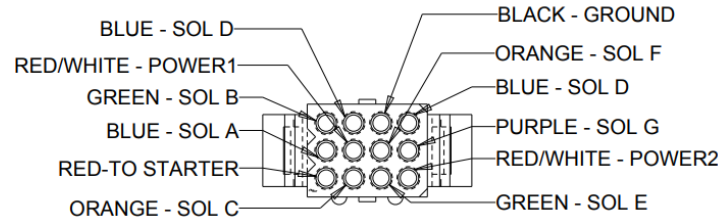

16160300 TRUCK HARNESS TO  
16162600 G1 CONTROLLER  
(HARNESS SIDE)

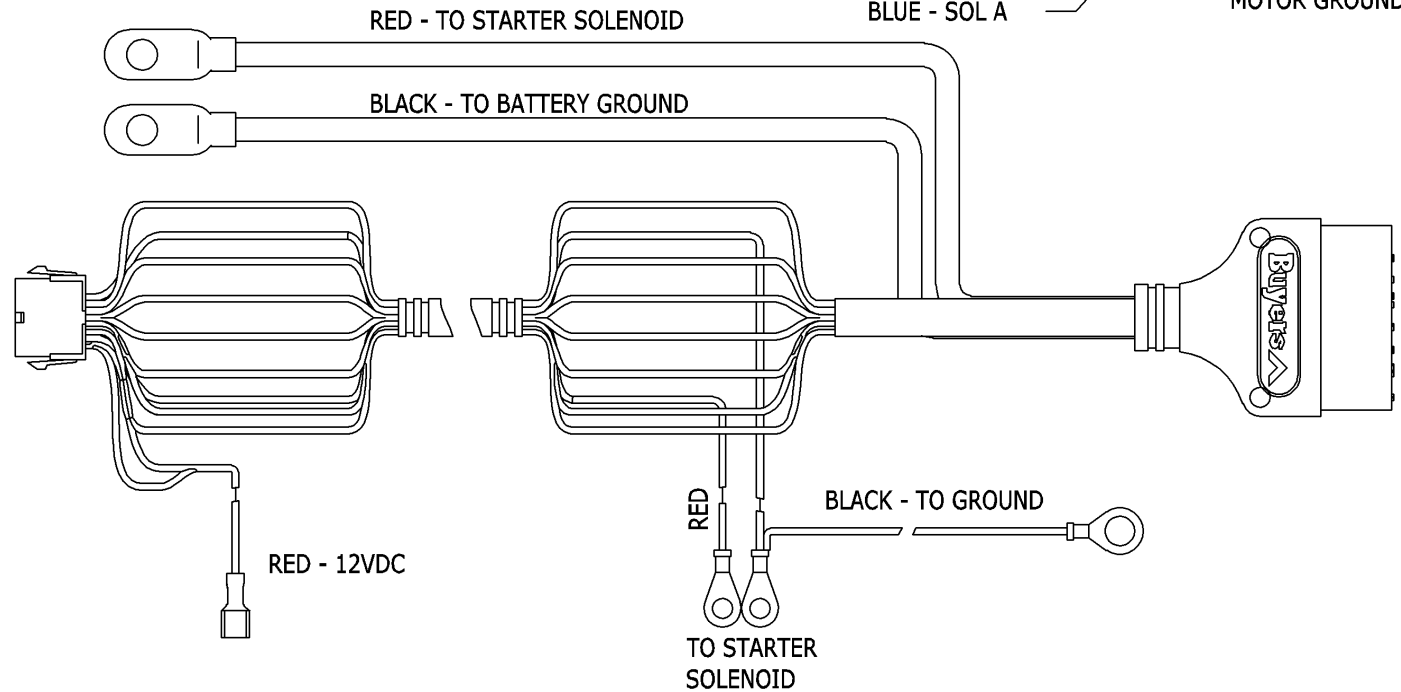
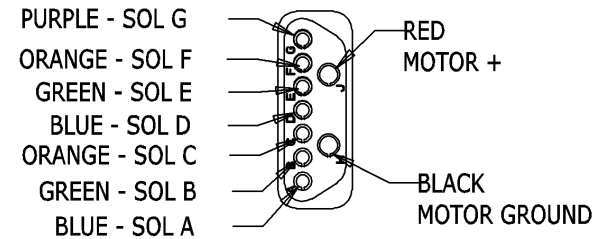
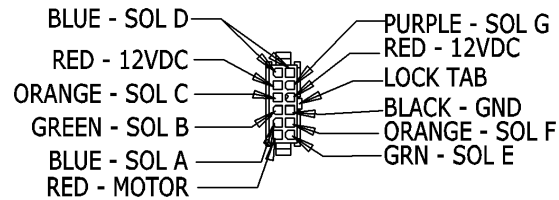

### PLOW HARNESS PINOUT

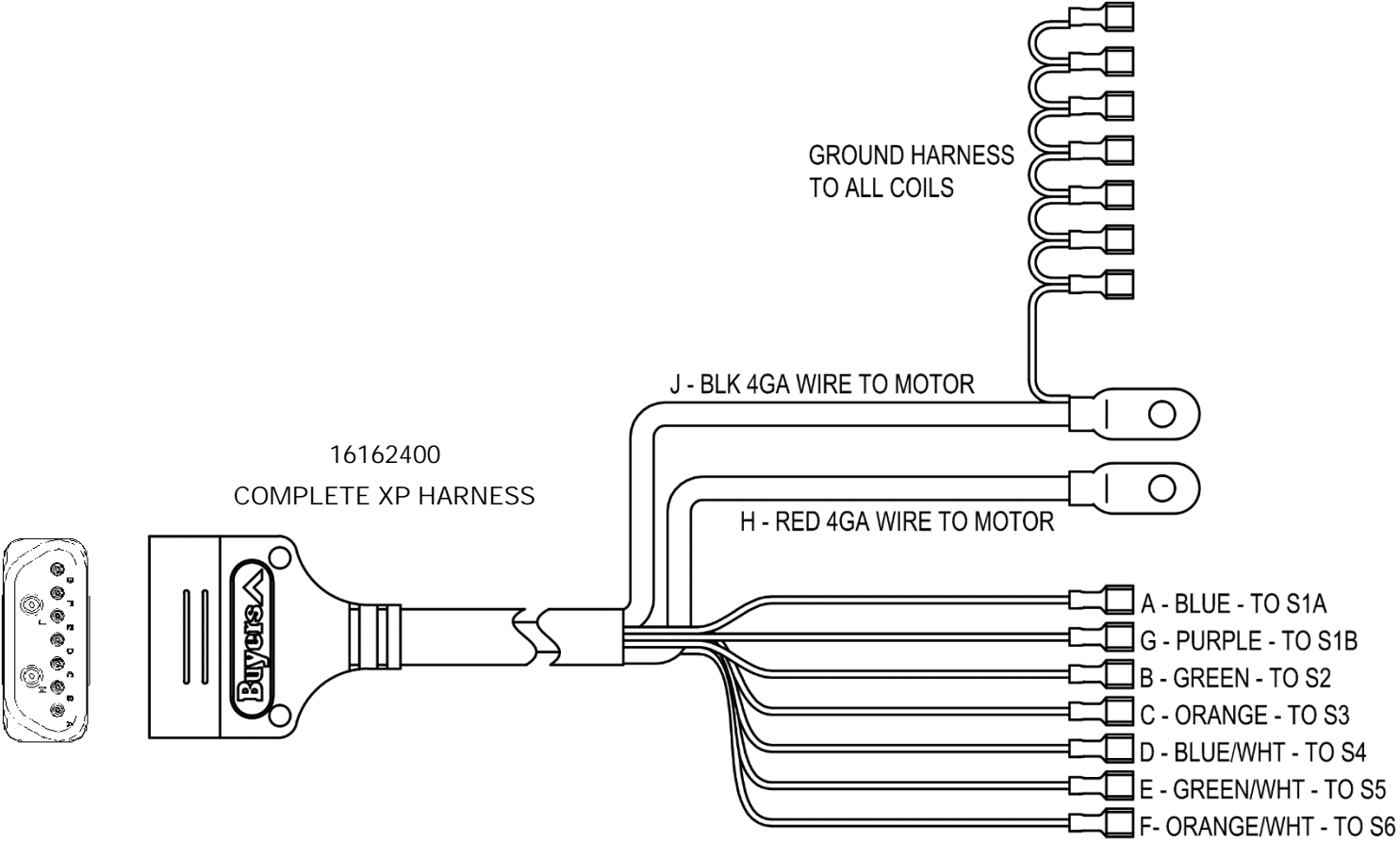

## SNOWDOGG CONTROLLER

The SnowDogg controller uses fault tolerant drivers that can withstand shorts to ground without failure. The failure of a single channel will not affect the performance of the remaining channels.

If the fault is intermittent it will be registered, but will not cause the controller to stop functioning.

There are two controllers that have been used with SnowDogg straightblade plows.

16162600 – G1 XP Controller

16162601B – G2 XP Controller w/Rapidlink

The 16162601B can be used with any Expanding blade SnowDogg. G1 plows will require use of a 16160370 adapter. Both controllers behave similarly with the exception of the integral diagnostics.

XP CONTROLLER OUTPUT TABLE  
16162600

	LOGIC TABLE							
PIN	MOTOR	A	B	C	D	E	F	G
CHANNEL	1	2	3	4	5	6	7	8
VALVE	MOTOR	S1A	S2	S3	S4	S5	S6	S1B
UP	X	X	-	-	-	-	-	
DOWN	-	-	-	-	-	-	-	X
FLOAT	-	-	-	-	-	-	-	X
LEFTIN	X	-	-	-	X	X	-	-
LEFTOUT	X	-	-	-	-	X	-	-
RIGHTIN	X	-	-	-	X	-	X	-
RIGHTOUT	X	-	X	-	-	-	X	-
ANGLEFT	X	-	X	-	-	-	-	-
ANGRIGHT	X	-	-	X	-	-	-	-

### 16162600 CONTROLLER DIAGNOSTIC MODE

Enter diagnostic mode with the following sequence.

1. Disconnect the controller from power (turn truck off)
2. Hold down the POWER button and turn truck on
3. Continue holding down POWER button until GREEN status LED begins to blink (10 seconds)
4. You are now in "Diagnostic" mode. All outputs are off.
5. Use the buttons/leds as shown to test each channel

- GREEN STATUS LED
  - Blinks the # of the channel currently selected
- RED STATUS LED
  - SOLID when selected channel is shorted
  - BLINKS when selected channel is open (broken)
- YELLOW STATUS LED
  - SOLID in any error condition in selected channel
- RIGHT
  - Increase the channel number being tested
  - This will turn off ALL channels
- LEFT
  - Decrease the channel number being tested
  - This will turn off ALL channels
- UP
  - Turns ON selected channel
- DOWN
  - Turns OFF selected channel

Exit diagnostic mode by turning the controller off and back on.

### 16162601B CONTROLLER DIAGNOSTIC MODE

Enter diagnostic mode with the following sequence.

1. Turn the controller off
2. Press and hold the UP button while pressing the ON/OFF button.
3. Release the UP button.
4. You are now in "Diagnostic" mode. All outputs are off.
5. Select the channel to test using the LEFT and RIGHT buttons.
6. Use the buttons/leds as shown to test each channel

- RIGHT/LIGHT
  - Increase the channel number being tested
  - This will turn off ALL channels
- UP
  - Turns ON selected channel (PLOW MAY MOVE)
- GREEN STATUS LED
  - Blinks the # of the channel currently selected
- RED STATUS LED
  - SOLID when activated channel is shorted
  - BLINKS 4 times if activated channel is open (broken)

Exit diagnostic mode by turning the controller off and back

# TROUBLESHOOTING

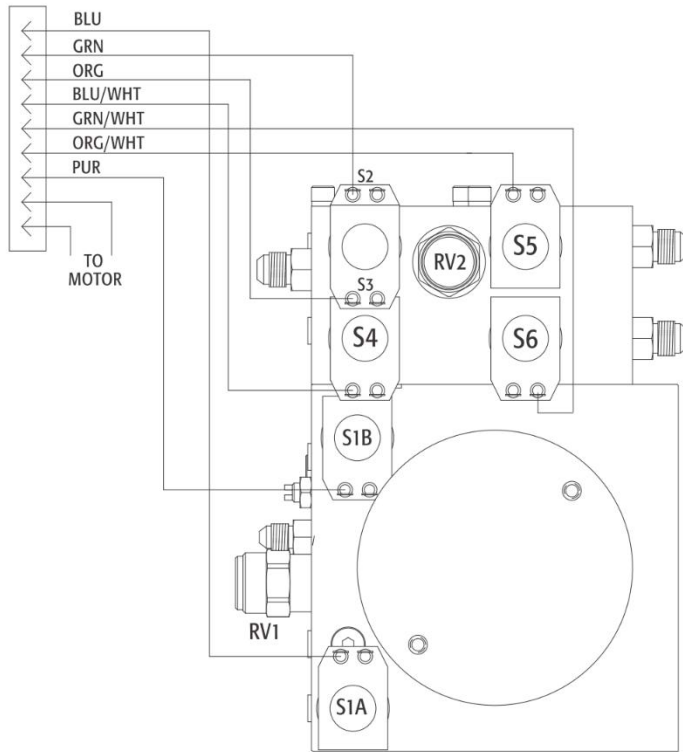

SOL	MOTOR	S1A	S2	S3	S4	S5	S6	S1B
UP								
DOWN								
FLOAT								
LEFT								
RIGHT								
LEFT IN								
LEFT OUT								
RIGHT IN								
RIGHT OUT								
BOTH IN								
BOTH OUT								

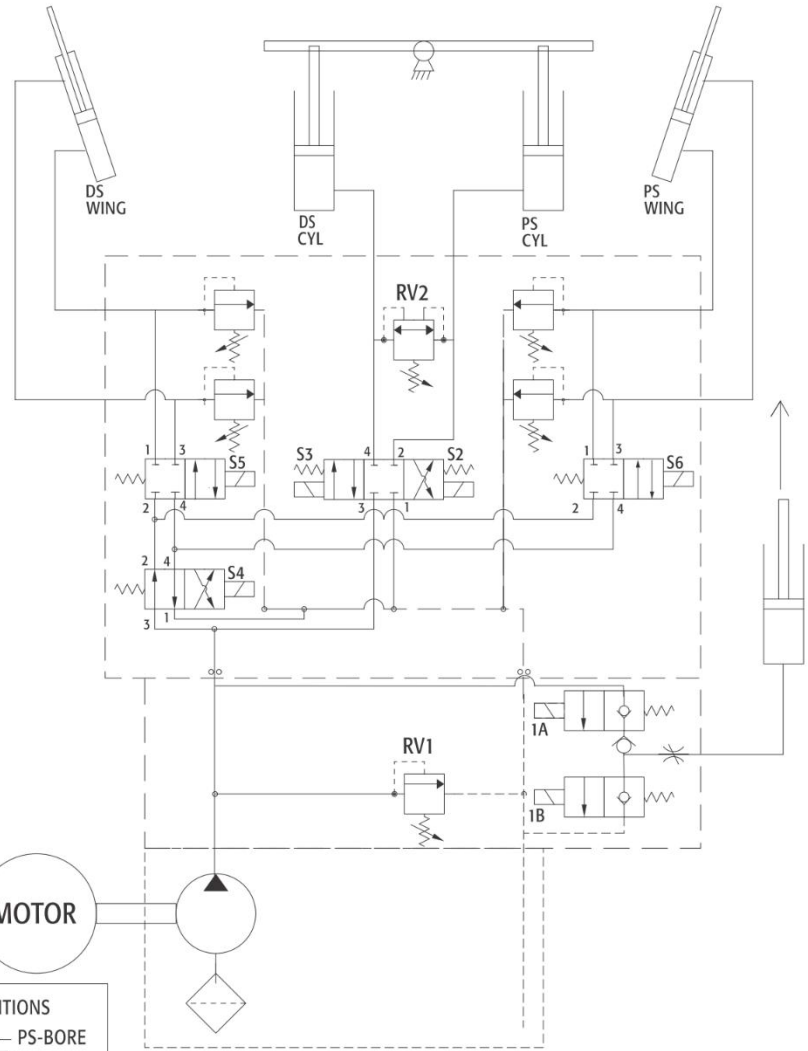
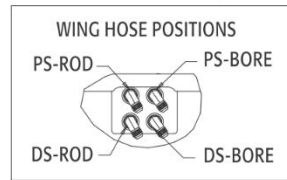

3015498 Rev A



